

SECTION 16400 - SERVICE AND DISTRIBUTION

PART 1 – GENERAL

1.1 SCOPE OF SECTION:

This section contains the requirements for equipment and installation relating to the distribution and control of electric power 600 volts and below. Includes, switchgear, switchboards, panel boards, bus ducts, transformers, and motor controls.

1.2 DISTRIBUTION SWITCHGEAR / SWITCHBOARDS:

- A. GENERAL: Switchgear and switchboards shall be equipped with a Main Breaker, unless protected by an upstream circuit breaker. In that case, provide a non-automatic disconnect switch and/or MLO panel. Electronic breakers with replaceable chips are not acceptable.
- B. All main switchboards and switchgear shall be of the circuit breaker design, unless written permission for fusing has been granted by PPD. If fusing, provide 10% spare fusing with a minimum of three spare sets (one set incorporates provisions for all the phases) of each size. Spare fusing shall be provided in weatherproof containers for long-term storage (such as in ammo cans). Spray paint container with the wording 'Spare Fuses' on the side.
- C. ACCEPTABLE MANUFACTURERS: General Electric; Square D; Cutler – Hammer; Siemens.

1.3 SAFETY SWITCHES / DISCONNECTS:

- A. All Safety Switches and Disconnects shall be Heavy Duty type.
- B. Provide 10% spare fusing with a minimum of three sets spare (including new fusing for each of the three phases) of the amount installed, based on the different voltages, amperage ratings, and types of fusing installed. Spare fusing shall be provided within weatherproof containers for long-term storage (such as in ammo cans). Spray paint container with the wording 'Spare Fuses' on the side.

1.4 CABLE TRAYS:

- A. Cable trays shall be adequately sized for 10% future additions (minimum). Cable trays shall be installed as high as possible, but beneath ductwork. Installed cable trays shall be accessible at all locations. Trays shall be installed with a cover only where physical protection of the installed cables is required, and where accessible. See UF Telecommunications Construction Standards for further requirements on telecommunications cable tray.
- B. Separators between different types of services shall be provided.

1.5 METERS AND INSTRUMENTATION:

- A. GENERAL:
 - 1. University Policy: It is the policy of the University that all utilities be metered. Utilities

include electricity, domestic water, chilled water, steam, and irrigation. All new buildings and renovations shall include installation of permanent metering of all utilities. Metering for new service shall be installed on a 6 inch wide by 4 inch deep by 8-feet high concrete post (or similar dimension) installed in concrete a minimum of three feet into the ground. Building switchgear or switchboard at the building's point of power entry (service) shall contain building metering as verification of the exterior revenue metering, and as a potential source of communicating load data information for future digital control of building systems.

2. Temporary Utilities: All utilities (including electricity) consumed during construction shall be metered and paid for with project funds. The Constructor shall be billed for consumption, unless specifically stated otherwise in writing. No utilities shall be consumed by any Constructor unless specifically permitted in writing by the Physical Plant Division.
3. Absent or Improper Metering: Installations found not to be metered or having incorrectly working meters, shall be disconnected from service immediately until properly working meters are installed. In the absence of metering, a flat rate based on the maximum connected load shall be charged. This calculation is solely at the discretion of PPD.

B. WATT-HOUR METERS: Watt-hour meters shall meet the following requirements:

1. Current transformer wiring shall be a minimum size #12 AWG up to 22 feet and #10 AWG when over 22 feet to reduce the burden on the metering circuit. All wiring shall be copper.
2. Potential wiring on transformer rated circuits shall be #14 AWG at all times to distinguish it from the current circuits. All wiring shall be copper.
3. Current transformer wiring and potential wiring shall be similarly color-coded: A phase - black; B phase - red; C phase - Blue; Neutral - white; Ground - green. Wiring for potentials and current transformers shall be identified with plastic sleeve wire markers. Cloth adhesive markers are not acceptable. For 480/277V: use brown, orange and yellow.
4. On transformer rated meters only, potentials shall be fused before entering meter can.
5. Transformer rated meters and meter cans shall be 13 terminal type and shall have manual circuit closing devices and test switches. Accepted manufacturer: Meter Devices Co. This is base only, specify meter.
6. All meters shall be tested by an independent testing agency for accuracy under "full load" and "light load" conditions. A test for accuracy and balance shall also be performed for individual stators under "full load" and "light load" conditions. A copy of the results shall be submitted to the Physical Plant Division. Verification of the proper meter multiplier shall be included in the test report.
7. Meters that are not 208/120 volt, 3 phase, "Y" or 240/120 volt, single phase, shall be marked accordingly. Meters shall also be marked with the proper multiplier for the installation. Meters shall have three full stators and digital displays.
8. Current transformers (C.T.s) shall be based on the size of the load and the rating factor of the C.T.s. For example: if the nighttime load was 20 amps and the maximum demand

was 300 amps, a C.T. with a rating factor of 2.0 and a ratio of 200:5 would be acceptable. A C.T. with dual ratio current range shall be selected when possible.

9. Meters shall be rated for the greatest class available when possible. Transformer rated meters shall be a class CL20 and self-contained meters shall be a class CL200 or CL 320.
10. Three phase, 4 wire Delta meters shall have the B phase or "high leg" located on the far right terminal.
11. Meter installations shall be inspected by PPD Operations Engineering prior to turning on power for compliance with these specifications. Any discrepancies shall be noted to the Constructor for action and a re-inspection shall be required prior to turning on power.
12. Current transformers shall be used when the maximum continuous load exceeds 400 amps. Transformer rated meters are preferred for 480-volt loads.
13. All new projects shall require Elster A3 ALPHA electrical meters. These meters shall have built-in 900 MHz RF communications. The meters will be configured into an AMR (automatic meter reading) system where A3 ALPHA nodes communicate via 900 MHz RF to A3 ALPHA collectors which in turn send data via IP to the main Metering Automation Server (MAS). PPD shall be contacted at least 6 weeks prior to needing electrical service. PPD Energy Dept. will purchase the meter and charge the appropriate project account.

There are four main types of meters involved:

- A. A3T Node: Services with small or insignificant load profiles. This meter will not be used as the normal basis for most UF projects.
 - B. A3TL Node: This shall be the default meter to be provided for most new projects. It includes load profile data in 15, 30 or 60 minute intervals. It communicates to Collectors via 900MHz RF. It also has a built-in RS-232 port which can connect to the optional IP Interface Module to communicate via LAN directly to the MAS.
 - C. A3TL Collector: This meter shall be used in lieu of the A3TL Node when directed by PPD. It has a built-in IP Module to communicate via LAN directly to the MAS. It also receives 900MHz RF signals from nearby Nodes and collects and transmits this data to the MAS.
 - D. A3TL-FT21 IP : This is a switchboard mount version of the A3TL IP meter that will require an IP connection. This meter is required at all substations and chiller plant switchboards and switchgear.
14. Electrical drawings shall provide a wiring diagram for meter installations including all devices used in the metering circuit.
 15. To prepare for future LAN communications from A3TL Nodes, projects installing the A3TL Node meter shall require an interface box near the meter for the future IP Interface Module. Most projects initially will only be required to provide the meter and associated boxes and conduit. The IP Interface Module and AMR system connections can be completed later by others. The IP Interface Module will require a Hoffman style, hinged, lockable, NEMA 3R box approximately 10"x10"x8". Installation of the 120 V power and the empty ethernet conduit should be part of the initial

installation. See attached sketch. One 1" conduit from the IP Interface Module box to the building interior communications / telephone room is to be provided by the Project. All A3 nodes are RF and shall to be pre-programmed with UF as the specific utility code LAN identification, code as known by Elster and through Byram Laboratories, Inc. Actual meter form configurations per ANSI standards will be whatever is required per the A/E's design documents.

16. Acceptable Manufactures: Elster.

1.6 **EMERGENCY GENERATORS:**

- A. Emergency generators shall be equipped with radiators for all new installations.
- B. Where existing conditions limit the amount of available space for new generators with radiators, the design and installation may include the remote mounting of radiators.
- C. Where conditions require matching existing conditions for potable water-cooling the generator, new units should accommodate both potable water-cooling systems and (remote) radiator cooling. The design and installation of these generator-cooling systems shall include valved piping, switchable between potable water and radiator cooling. Please confirm with Physical Plant Department the exact requirements based upon the installation. For example, generators at the Health Science Center in the Communicore and Dental wing have potable water cooling.

END OF SECTION

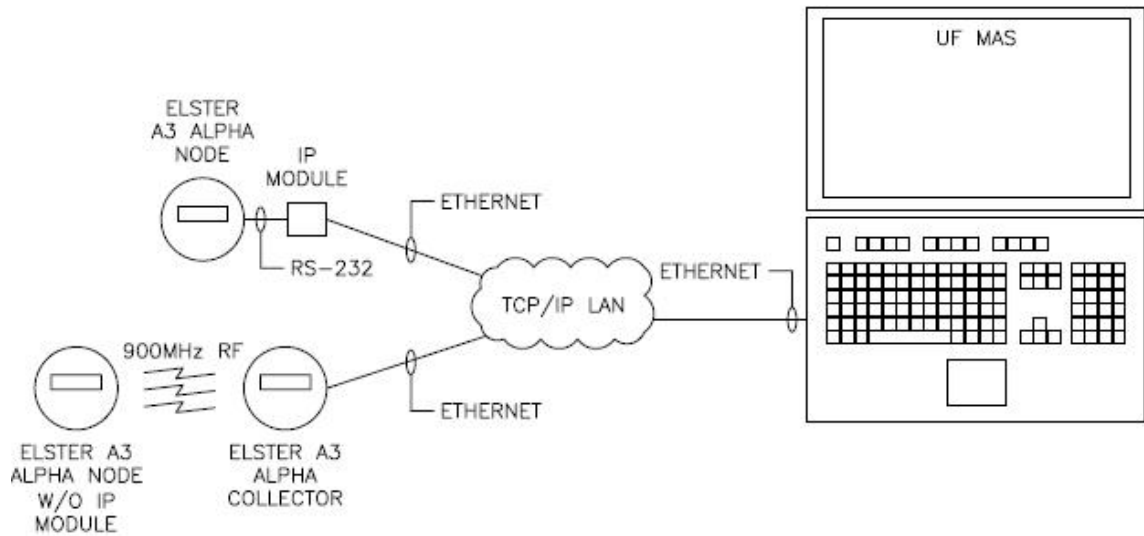

TYPICAL UF AMR DIAGRAM

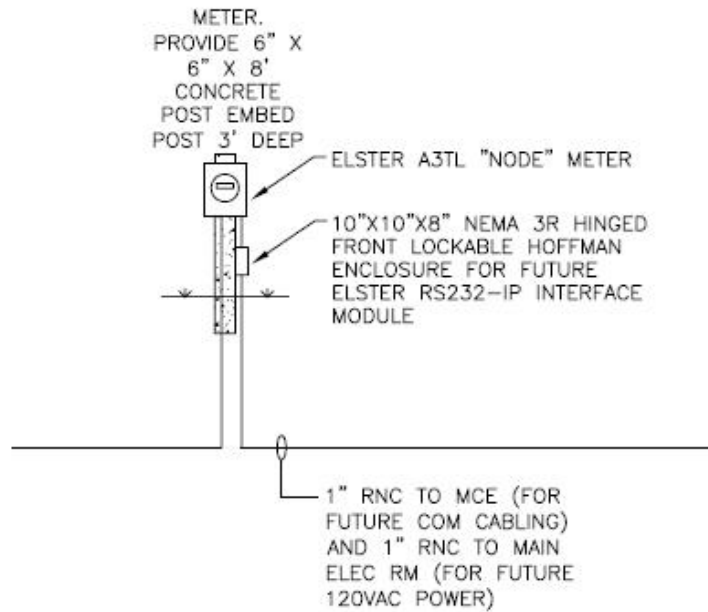

TYPICAL UF METER FOR PAD MNT XFMR